

Retrofit External Pole Mount System with Permanent Mounted Lowering Tool \*  
Manual System suitable for Outdoor use rated for 20-400 lbs.

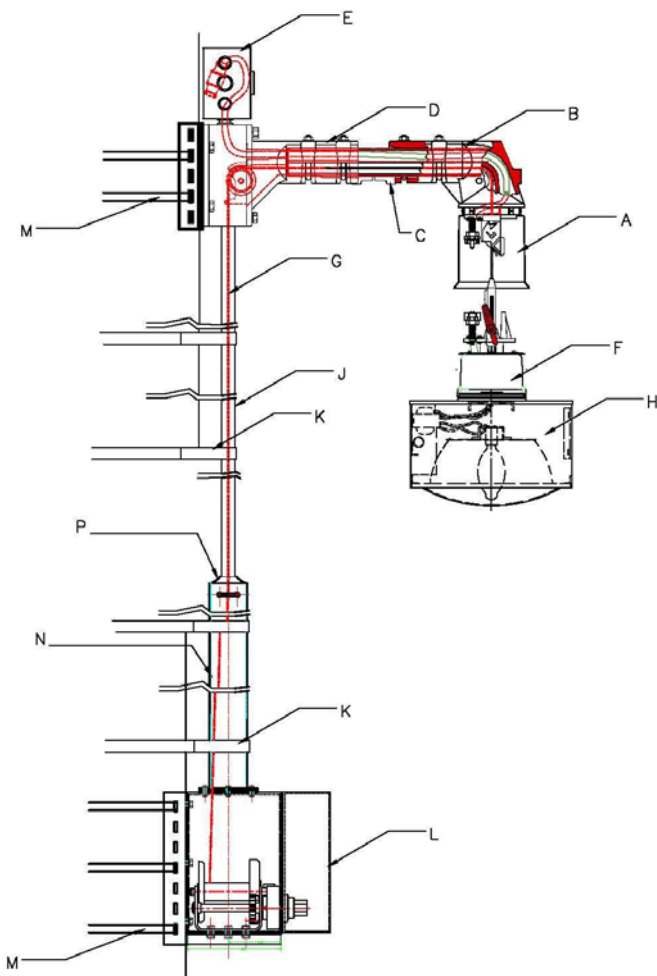

- A. ELECTRICAL AND SIGNAL DISCONNECT UNIT WITH MULTI-PIN CONNECTOR.**
- B. DISCONNECT UNIT FITTER WITH PULLEY AND U-BOLT MOUNTING.**
- C. DIVIDED PIPE ARM: 2-3/8 IN. O.D. SEPARATES CONTROL CABLE AND ELECTRICAL/SIGNAL WIRES.**
- D. POLE MOUNTED FITTER WITH PULLEY HOUSING AND MOUNTING BRACKET FOR STRAP MOUNTING TO POLE (STRAPS BY OTHERS).**
- E. ELECTRICAL CONNECTION BOX (OPTIONAL).**
- F. LIGHTING CONNECTION BOX (OPTIONAL).**
- G. CONTROL CABLE CONSTRUCTED OF 5/32 INCH DIA. STAINLESS STEEL 7X19 CABLE.**
- H. LIGHT FIXTURE (OPTIONAL).**
- I. 1 1/4" CONDUIT (BY OTHERS).**
- J. CONDUIT CLAMPS AS PER REQUIREMENTS (BY OTHERS).**
- K. PERMANENT MOUNT LOWERING TOOL WITH WINCH HANDLE IN 316 STAINLESS STEEL ENCLOSURE. (LOCK BY OTHERS).**
- L. POLE-BELTS (BY OTHERS) AS PER REQUIREMENTS.**

Details shown are intended as an application example only. Actual installation details may vary. Contact manufacturer's representative or factory for specific details about special installation application or other information. Lifting capacity is 400 lbs and must not be exceeded. Disconnect unit support must be horizontal.

\*\* Specifications subject to change without notice.

**RETROFIT EXTERNAL POLE MOUNT SYSTEM.**

- A. THE EPM SYSTEM IS AN EXTERNAL POLE MOUNT SYSTEM ALLOWING THE LOWERING SYSTEM TO BE USED ON EXISTING POLES.
- B. EPM-PMT UTILIZES A PERMANENT MOUNTED GEAR BOX INSIDE A MARINE GRADE HEAVY DUTY TYPE 316 STAINLESS STEEL CABINET. THE SYSTEM ALSO PROVIDES A STAINLESS STEEL 3" PIPE, 4 FEET IN HEIGHT.
- C. THIS SYSTEM IS PRESENTLY BEING USED BY THE FLDOT, MIAMI DISTRICT AND IDOT. DUE TO THE EXTREMELY CORROSIVE ENVIRONMENT, THE MARINE GRADE STAINLESS STEEL IS THE BEST TYPE OF MATERIAL FOR PROTECTING THE LOWERING TOOL FOR THE SEVERELY CORROSIVE ELEMENTS.
- D. WHEN NOT IN USE, THE WINCH HANDLE IS KEPT IN THE CABINET.
- E. A DRILL WITH CLUTCH CAN ALSO BE PROVIDED WITH THE SYSTEM.
- F. SPECIAL HEAVY DUTY BRACKET IS ALSO PROVIDED ON BASE OF CABINET AND ATTACHED TO THE VERTICAL MOUNTING BRACKET. VERTICAL BRACKET HAS SLATS FOR STRAPS TO ATTACH FRAME TO POLE.
- G. SYSTEM ALSO AVAILABLE WITH A PORTABLE TOOL.

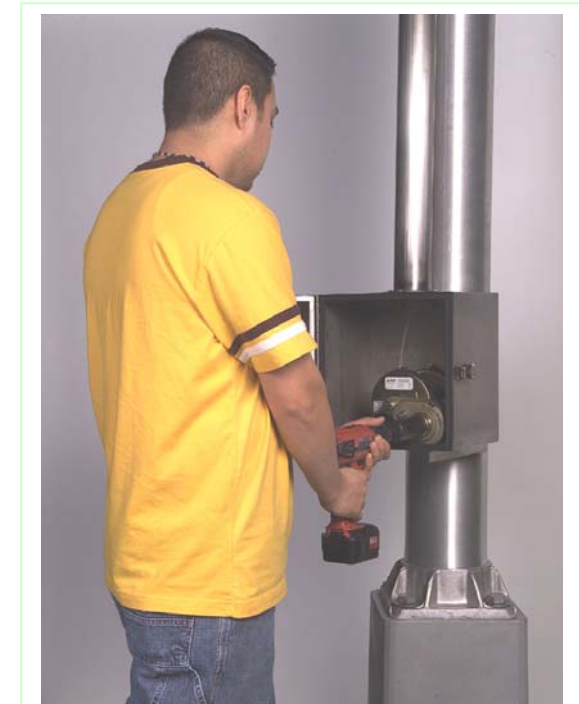

# Permanent Mounted Lowering Tool

## LT-DRI-CL Drill motor with clutch

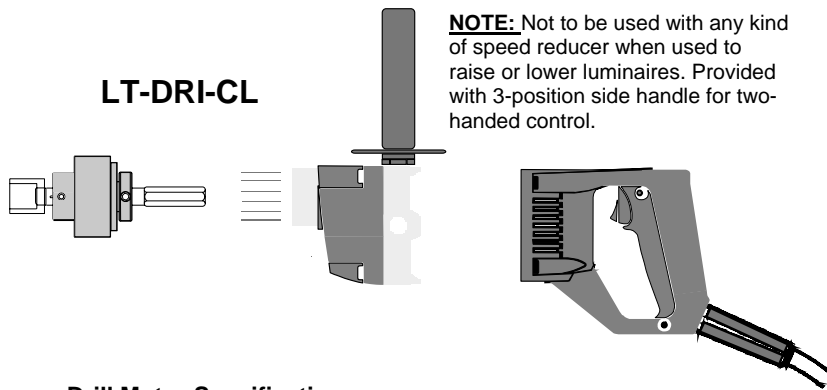

**NOTE:** Not to be used with any kind of speed reducer when used to raise or lower luminaires. Provided with 3-position side handle for two-handed control.

### PERMANENT LOWERING TOOL



#### Drill Motor Specifications

- Drill is 1/2" double insulated, heavy duty, reversible, variable speeds, with 'D' handle.
- Chuck size is 1/2" key chuck with key.
- Electrical-Nom. 5 amp universal motor 115v.AC
- Torque-Develops nominal 170 lbs.-in.
- Speed/HP-.5 H.P. No load speed of 350 RPM
- Overall length is 15-1/8"
- Weight: Approx. 7lbs. 6oz.

#### Overload Clutch Specifications

- Lubricated ball indent-totally enclosed-adjustable torque limiting.
- Coil spring type. Varied quantities depending on torque range. Torque range: 60 to 300 lb./in.
- Winch drive is 1-1/8" hex socket with 1/2" sq. drive.
- Max. operating speed is 350 RPM
- Dimensions of clutch: 1 1/2"Dia., 1 5/8"L. Overall, 8 1/2"L
- Hub shaft: 3/8" sq. w/spring loaded pin (clutch end).
- Socket shaft: 3/8" sq. w/spring loaded retaining pin.
- Open-end wrench type torque-adjusting nut. Snap ring tool included with clutch.
- Clutch weight: 2 lbs.

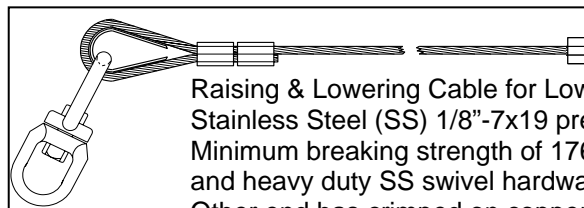

Raising & Lowering Cable for Lowering Tool. Made of Stainless Steel (SS) 1/8"-7x19 preformed aircraft cable. Minimum breaking strength of 1760 lbs. Comes with loop and heavy duty SS swivel hardware cable attachment. Other end has crimped on copper stop.